

Model MRG

Multi-Range General Pressure Transducer

The Setra Model MRG is Setra's newest differential pressure transducer. The Setra MRG is the ideal product for any contractor, combining the flexibility of a multi-range with the performance of a single range transducer. The MRG has 8 selectable ranges and 3 selectable outputs, easily adjustable on the job with a flip of a switch or jumper. The MRG uses an IP67 rated housing and has a conduit fitting for easy wiring, making the MRG an ideal solution for any general HVAC application.

Universal Design

The Setra MRG utilizes a universal design that gives the user total flexibility to make changes on the job site. The user has the option to choose the field configurable range, mounting (DIN Rail, wall mount and duct mount), output (mA or Volt) and engineering unit (W.C. or Pascals). This flexibility means that the contractor can use the MRG for all of their needs.

8 Field Selectable Ranges

The Setra MRG provides 8 field selectable ranges (0.5, 1.0, 2.5 and 5.0"W.C.). These ranges can be selected on site by flipping to the desired range.

IP67 Rated Housing

The MRG housing is a robust IP67 rated design and is sealed with a gasket to make it wash-down capable for difficult applications. The MRG also has a conduit fitting that make installation and wiring easier.

Capacitive Sensing Technology

Only Setra can claim ownership to the stainless steel capacitive design used in all of our HVAC/R sensors. Our advanced capacitive element provides excellent stability and linearity, while standing above the competitors in our ability to measure low pressure (<0.001"W.C.) at high accuracy. Our technology has been used in over 8 million installations and has the highest field acceptance rate in the industry.



- Universal Design
- IP67 Rated Housing
- Field Selectable

Model MRG Features:

- Field Configurable Duct Probe
- 4 Digit LCD
- Field Selectable Range
- Field Selectable Output
- Simple 5-Step Setup
- Field Accessible Push-Button Zero & Span
- External Mounting Tabs & Optional DIN Rail
- Unregulated AC/DC Operation

Target Uses:

- Sub-Contractors- Quick Installation
- Flexible for Building Specification Changes
- Service/Retrofit Friendly
- Service Technicians- Quick & Accurate Reconfiguration

Model MRG

Mutli-Range General Pressure Transducer



ORDERING INFORMATION

M	R	-	G	-		-	
Model	Field Selectable Ranges				Configuration		Electrical Fitting
MRG	Unidirectional Pressure Ranges		Bidirectional Pressure Ranges		S	Standard (Base Mount)	A 1/2" Conduit
	0.5"W.C.	100 Pa	±0.5"W.C.	±100Pa	U	Universal ¹	P PG9
	1.0"W.C.	250 Pa	±1.0"W.C.	±250 Pa	D	DIN Rail	C 1/2" Conduit W/ Cal Certification ²
	2.5"W.C.	500 Pa	±2.5"W.C.	±500Pa	P	Duct Probe	D PG9 W/ Cal Certification ²
	5.0"W.C.	1,000 Pa	±5.0"W.C.	±1,000Pa			

¹Code U, Universal unit includes Duct Probe and DIN Rail options.

²Calibration is performed at highest range.

Ordering Example: MRGSA = Model MRG, Standard Configuration, with 1/2" Conduit.

DIMENSIONS

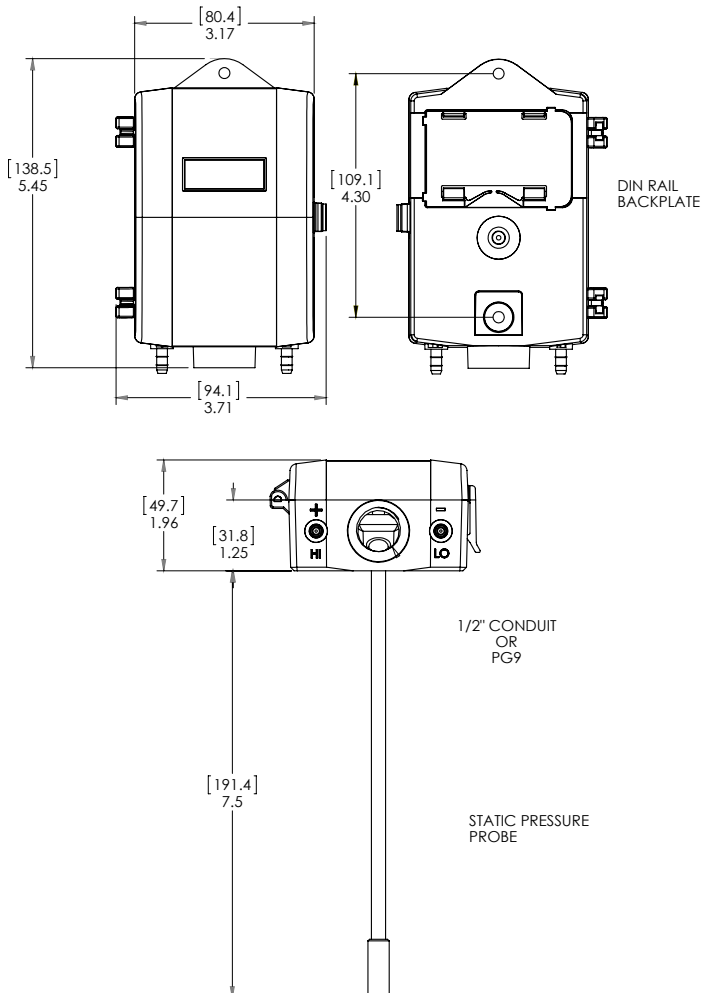

GENERAL SPECIFICATIONS

Performance Data		Environmental Data	
	Standard	Operating Temperature ³	32 to 122°F (0 to 50°C)
Accuracy RSS ¹ (at constant temp)	±1.0% FS	Electrical Data	
Compensated Range °F (°C)	32 to 122°F (0 to 50°C)	Excitation Range	13 to 30 VDC/18 to 24 VAC (Voltage Output) 13 to 30 VDC (4 to 20mA output at terminals)
Thermal Effects ² %FS/°F(°C)	0.03 (0.054)	Current Consumption	30mA (max)
Maximum Line Pressure	10 PSI	Mis-Wiring	Reverse Excitation Protection
Overpressure	Up to 10 PSI (range dependent)	Field Selectable Output ⁴	0 to 5V, 0 to 10V (3-wire), 4 to 20mA (2-wire)
Long Term Stability (max.)	2.0% FS/YR	Output Resistance (Voltage Output)	10 Ohms (max)
Position Effect		Load Resistance (Voltage Output)	10 K-Ohms (min)
Zero Offset %FS/G	0.5%	Loop Resistance (4-20mA)	0 to 800 Ohms
(Unit is factory calibrated at 0g effect in the vertical position)		Approval	CE & RoHS Compliant
Physical Description		Pressure Media	
Case	Fire-Retardant Polycarbonate (UL 94 V-0 Approved), Hinged Lid	Typically air or similar non-conducting gases.	
Mounting	Two Screw Holes Vertical Position	¹ RSS of Non-Linearity, Hysteresis, and Non-Repeatability. ² Units calibrated at nominal 70°F. Maximum thermal error computed from this datum.	
Electrical Connection Block	Removable Screw Terminal	³ Operating temperature limits of the electronics only. Pressure media temperatures may be considerably higher.	
Pressure Fitting	3/16" O.D. Barbed Brass	⁴ Calibrated into a 50K ohm load, operable into a 10K ohm load or greater.	
Zero	Push Button	⁵ Span (Full Scale) output factory set to within 1%.	
Span	Push Button	⁶ Calibrated at factory with a 24VDC loop supply voltage and a 250 ohm load.	
Weight (approx.)	8 Ounces	⁷ Span (Full Scale) output factory set to within ±0.16mA.	
Specifications subject to change without notice.			